

R&S® PR100

Portable Receiver

On-site radiomonitoring from 9 kHz to 7.5 GHz



75 Years of
Driving
Innovation



R&S®PR100

Portable Receiver

At a glance

The R&S®PR100 portable receiver has been specifically designed for radiomonitoring applications in the field. The receiver's functions and control concept have been optimized for monitoring tasks. In addition, it can be used for a variety of other applications.

R&S®PR100, top view: Maximum operating ease in a compact box



R&S®PR100 with R&S®HE300 active directional antenna: The antenna comes with three modules that cover the frequency range from 20 MHz to 7.5 GHz (can be expanded to 9 kHz with optional HF module). The preamplifier is accommodated in the grip piece.

The R&S®PR100 operates in a wide frequency range from 9 kHz to 7.5 GHz. Whether used for monitoring emissions, detecting interference or locating miniature transmitters, the receiver always combines high mobility with maximum operating ease. The receiver and the R&S®HE300 active directional antenna together form a compact receiving system. The receiver can also be used in conjunction with other antennas, e.g. broadband omnidirectional antennas.

Despite its compact design, the R&S®PR100 offers a wide range of functions otherwise available only in equipment in the higher price segments. Its favorable price/performance ratio makes it an indispensable instrument in all radiomonitoring tasks where high mobility and cost-efficiency are crucial.

Featuring compact size and low weight, the R&S®PR100 is ideal for use in places that cannot be accessed with a vehicle. Its low power consumption allows the receiver to operate for up to four hours on a single battery charge. The lithium-ion battery can be exchanged in a matter of seconds without requiring any tools. Current instrument settings are automatically written to the internal memory when the receiver is switched off.

- Fast panorama scan across the entire frequency range from 9 kHz to 7.5 GHz
- 10 MHz IF spectrum and demodulation with bandwidths from 150 Hz to 500 kHz
- Spectrum and spectrogram (waterfall) display on 6.5" color screen
- Storage of measurement data to SD card in receiver
- LAN interface for remote control and data output
- Ergonomic and rugged design for portable use
- Low weight of 3.5 kg (including battery)
- Location of emissions by means of R&S®HE300 active directional antenna



R&S®PR100

Portable Receiver

Applications and key features

Applications

Interference detection and location in professional radio networks

- Reliable detection of radio interference caused, for example, by defective electronic equipment
- Fast and effective elimination of interference sources, e.g. at airports

Monitoring of user-specific radio services

- Monitoring of a large number of radio services by means of different scan modes
- Monitoring of an organization's own emissions in an assigned frequency band

Homing of emergency signals

- Location of source of emergency call by means of the R&S®HE300 active directional antenna
- Tone function for source location in difficult terrain

Homing of improvised explosive devices (IED)

- Detection of IEDs even when they operate in standby mode
- Location of IEDs with the R&S®HE300 active directional antenna

Mobile tracking of miniature transmitters

- Detection of bugs, e.g. in conference rooms
- Homing of bugs by means of the R&S®HE300 active directional antenna

Key features

Future-proof investment

- Its wide frequency range and outstanding performance make the receiver a future-proof investment
- The R&S®PR100 is capable of receiving and processing signals of current and future radio services

High receiver sensitivity, high signal resolution

- Using state-of-the-art digital signal processing, the R&S®PR100 can receive signals with high sensitivity and detect even extremely weak signals without any loss in processing speed
- The receiver features sensitivity and signal resolution clearly superior to those of a conventional analog receiver

Retrieval of information through demodulation

- Signals with analog modulation are demodulated directly in the receiver, and their contents can be audio-monitored by means of headphones or the built-in loudspeaker
- Digitally modulated signals are converted to the base-band by means of I/Q demodulation and stored in the receiver or exported via LAN
- The digitally modulated signals can subsequently be analyzed offline, e.g. by means of the R&S®GX430 software from Rohde&Schwarz

Detection of pulsed signals and radar emissions

- The R&S®PR100 can capture short-duration pulses, e.g. of radar emissions
- The receiver's wide IF bandwidth allows the spectrum of those short pulses to be analyzed

Monitoring receiver and mobile data memory in a single unit

- Collected information is written to the receiver's built-in SD card; no additional equipment is required
- Data recorded during monitoring can subsequently be analyzed offline

Efficient operation via remote control

- The R&S®PR100 can be fully remote-controlled via the LAN interface (SCPI commands to IEEE488.2)
- This allows efficient, remote operation of the receiver, e.g. in unattended monitoring stations

Intuitive and convenient operation

- The straightforward menu structure and high operating convenience help users to familiarize themselves quickly with the instrument
- The received signals are shown on a 6.5" color display and can be conveniently analyzed

Battery operation for mobile use

- Low weight of 3.5 kg including battery
- Operates four hours on a single battery charge

Interference detection and location in professional radio networks

Its compact design and wide range of special functions make the R&S®PR100 an ideal choice for tracking all types of radio interference.

Reliable detection of radio interference caused, for example, by defective electronic equipment

To master these tasks, the R&S®PR100 includes special functions such as selectable measurement time and continuous or periodic level output. Since these functions are also effective in the panorama scan mode, you can easily detect even non-periodic interferers which are otherwise difficult to recognize due to their irregular appearance in a quickly changing spectrum.

Fast and effective elimination of interference sources, e.g. at airports

By using the R&S®HE300 active directional antenna together with the R&S®PR100 portable receiver, you can quickly and reliably locate the source of an interference and eliminate it. This is especially important in security-critical radio scenarios (e.g. air-traffic control, ATC), and saves the service provider high failure costs. The fast panorama scan is ideal for this task.

In the panorama scan mode, the frequency range of interest is traversed in steps of max. 10 MHz. An FFT of corresponding width is calculated for each step. Maximum scan speed is achieved by selecting the maximum spacing of 100 kHz between the points for FFT calculation.

This provides a quick overview of the spectrum occupancy. Any changes caused by illegal radio services, interference sources, temporary emissions, etc. are easy to recognize. If the user stops the panorama scan, the receiver switches to the audio-monitoring mode. Using the marker function, a signal of interest can be selected, demodulated, and the signal content analyzed.

The step width for the fast panorama scan can be chosen to match the channel spacing of a variety of radio services. The panorama scan provides high scan rates at narrow resolution bandwidths and thus high sensitivity.



Interference in radiocommunications, e.g. at airports, not only impedes operation – it may even pose a threat to life

Monitoring of user-specific radio services

The frequency scan mode is mainly intended for monitoring radio services that use fixed channel spacing.

Smooth operation of one's own radio networks is vital to ensure operational readiness – not only for organizations accomplishing governmental tasks



Monitoring of a large number of radio services by means of different scan modes

In the frequency scan mode, a user-defined frequency range is scanned using a fixed channel spacing. The receiver steps through the frequency range of interest and checks every channel as to whether any signals are present.

If a signal is detected that exceeds the predefined level threshold, the receiver dwells at the corresponding frequency for the set hold time, allowing for the signal to be demodulated and processed. In the case of analog modulation, the demodulated signal can be monitored via the loudspeaker or headphones.

In the memory scan mode, predefined channels stored in memory locations are consecutively scanned and analyzed as to whether any signals are present. The R&S®PR100 offers 1024 user-definable memory locations. Receive parameters can be assigned separately to each memory location.

The memory scan mode is especially useful for scanning individual frequencies that do not have fixed channel spacing or that use different modulation modes and bandwidths. The memory scan mode thus offers the user a greater degree of freedom than the frequency scan mode.

Monitoring of an organization's own emissions in an assigned service band

- Shortwave communications
- Tactical communications
- Air traffic control (ATC)
- TETRA
- Demodulation, e.g. of broadband TETRA with 200 kHz channel bandwidth
- 433 MHz/868 MHz/2.4 GHz ISM bands
- GSM 900/1800/1900
- AMPS/DECT/UMTS
- Bluetooth®/WLAN
- WiMAX/WiFi
- RFID/ZigBee

Homing of emergency signals

Transmitters can be tracked not only visually by displaying the received signal level or the spectrum, but also acoustically by means of the tone function.

Location of source of emergency call by means of the R&S®HE300 active directional antenna

For example, if an emergency transmitter has been identified at a specific frequency, the user can activate the tone function in order to locate the transmitter. This function causes the receiver to output a whistling tone whose pitch varies with the level of the signal received. The signal level, in turn, varies as the user changes position or points the antenna in various directions.

Tone function for source location in difficult terrain

The acoustic level indication allows the user to fully concentrate on the terrain and on tracking the transmitter as there is no need to continuously monitor the receiver display.

If a person in distress has been located by means of the R&S®PR100 and the R&S®HE300, the position information is immediately forwarded to the rescue team



Location of improvised explosive devices (IED)

By approaching the signal source, the R&S®PR100 can locate even extremely weak signals in difficult terrain.

Detection of IEDs even when they operate in standby mode

For example, the oscillator reradiation of a IED is visible on the display of the R&S®PR100 even if the device is operating only in receive mode. The receiver of a remote detonation device leaves traces in the frequency spectrum even in standby mode. Oscillator reradiation and other spurious effects caused by remote-control electronics are unintended emissions. They tend to occur more frequently in semi-professional equipment as used, for example, to detonate improvised explosive devices.

Homing of IEDs with the R&S®HE300 active directional antenna

The R&S®PR100's wide receive frequency range proves very helpful when it comes to detecting emissions of this kind as the spectral range of interest is not exactly known at the beginning of a monitoring task. The receiver features a preselection function, which yields valuable results even in environments characterized by strong noise or strong signal levels close to the frequency of interest. The preselection function limits the signal sum level to be handled by the receiver. It thus provides effective signal detection in battlefield scenarios that are highly loaded in terms of frequency and level.

Low weight and long battery operating time for mobile applications

The R&S®PR100 operates for an average period of four hours on a single battery charge. This makes it suitable for all kinds of portable radiomonitoring applications. Weighing only about 3.5 kg, it can be easily carried in a convenient chest strap.



Tracking telltale signals by means of the R&S®PR100 and the R&S®HE300 active directional antenna

Mobile tracking of miniature transmitters

The R&S®PR100 portable receiver offers high mobility plus a convenient carrying strap, making it perfectly suited for all kinds of mobile applications.

Finding bugs by means of the R&S®PR100 and the R&S®HE300 active directional antenna



Detection of bugs, e.g. in conference rooms

The R&S®PR100 can easily detect all types of miniature transmitters (bugs) as the receiver approaches them. Its wide frequency range of 9 kHz to 7.5 GHz covers the frequency bands of the majority of miniature transmitters used today.

For frequencies above 7.5 GHz, an R&S®HF907DC frequency-converting, portable directional antenna from Rohde&Schwarz can be used to expand the receive frequency range up to 18 GHz.

Location of bugs by means of the R&S®HE300 active directional antenna

The R&S®PR100 offers a differential mode function to facilitate signal detection. The current spectrum can be stored as a reference spectrum by pressing the associated key during the panorama scan. The receiver then displays any signal variations as a differential spectrum relative to the reference spectrum. Any new or changed signals can thus be recognized at a glance. The intensity of the signals emitted is strongly dependent on direction especially in close vicinity of miniature transmitters. The differential mode function is therefore a valuable aid in tracking these transmitters.

Another efficient tool for locating miniature transmitters is the tone function of the R&S®PR100. This function outputs a whistling tone whose pitch varies with the level of the signal received. This facilitates locating the signal source as the user need not continuously watch the receiver display.

Future-proof investment

The receiver's wide frequency range and outstanding performance make it a future-proof investment. The R&S®PR100 is capable of receiving and processing signals of current and future radio services.

High receiver sensitivity, high signal resolution

Using state-of-the-art digital signal processing, the R&S®PR100 can receive signals with high sensitivity and detect even extremely weak signals without any loss in processing speed. The receiver features sensitivity and signal resolution that are clearly superior to those of a conventional analog receiver.

The R&S®PR100 with fold-out stand for desktop use



Retrieval of information through demodulation

Signals with analog modulation can be demodulated in the receiver. The signal is audible on the built-in loudspeaker or via headphones. Complex baseband signals can be recorded internally or externally for offline analysis. The PC-based R&S®GX430 analysis software is available for both online and offline signal analysis. The data to be analyzed is transferred to a PC via LAN. The demodulation bandwidth can be selected independently of the IF bandwidth.

Detection of pulsed signals and radar emissions

Due to the large IF bandwidth of 10 MHz, even very short pulses and pulse packets (bursts) and the resulting very wide spectrum can be detected and analyzed. Burst signals of this type are typically emitted by radar equipment.

Monitoring receiver and mobile data memory in a single unit

The receiver provides the following internal storage media and functions for recording measured data:

- 64 Mbyte RAM for recording I/Q data up to 500 kHz bandwidth or audio data up to 12.5 kHz bandwidth
- 4 Gbyte SD card for storing recorded I/Q data, audio data, spectra and measured data
- The SD card is read out via the USB interface or an external SD card reader
- Digital audio data is recorded in WAV format, measured values in CSV format, and screenshots of the display can be stored in PNG format to the SD card
- Digital data can be output online via the LAN interface and recorded externally (e.g. on a PC hard disk)
- Buffering of data is not necessary

Efficient operation via remote control

The receiver can be fully remote-controlled via its LAN interface. This allows efficient, remote operation of the receiver, e.g. in unattended monitoring stations. The LAN interface is capable of handling the maximum data rate for the transfer of measured data. The protocol of the LAN interface is compliant with the IEEE 488.2 SCPI standard.

Battery operation for mobile use

- Low weight of 3.5 kg including battery
- Operates approx. four hours on a single battery charge

Intuitive and convenient operation

The operating concept of the R&S®PR100 meets the requirements placed on a modern radiomonitoring receiver, i.e. all important functions such as demodulation modes, bandwidths, etc. can be set directly by means of clearly labeled keys. Users will thus familiarize themselves quickly with the receiver.

The receiver is controlled conveniently via keys and the rotary knob. Clearly structured menus provide quick access to the instrument parameters and functions.

Results as well as the spectrum and waterfall diagrams can be read at a glance from the bright and straight-forward 6.5" VGA color display. The backlighting of the display can be dimmed for use in dark surroundings. For use in sunlight, a special black-and-white display mode is available that provides optimum contrast.

The IF panorama display allows the detailed analysis of a frequency range of interest. The current receive frequency is positioned at the center of the spectrum display. IF bandwidths between 10 kHz and 10 MHz can be selected for optimal adaptation to the task at hand. The AVERAGE, MIN HOLD and MAX HOLD functions further expand analysis capabilities.

The result display can be set to suit the particular requirement. Measured data is available in various formats. Digital data is output via the LAN interface:

- Complex baseband data (I/Q data) up to 500 kHz bandwidth
- Digital audio data up to 12.5 kHz bandwidth



All important functions such as demodulation modes, bandwidths, etc. can be set directly by means of clearly labeled keys provided both on the top and on the front of the receiver

Operation of the R&S®PR100 from the top



- ▮ Spectra of panorama scan (maximum refresh rate)
- ▮ Spectra of IF panorama display (maximum refresh rate)
- ▮ Measured signal levels
- ▮ Measured frequency offset values
- ▮ Measured field strength values (antenna factors of antenna used must be stored in the receiver)

Analog data is output via the corresponding analog interface:

- ▮ Analog audio data via 3.5 mm jack
- ▮ 21.4 MHz uncontrolled IF via BNC socket (for receive frequencies from 20 MHz to 7.5 GHz)

The user settings, e.g. attenuator modes (on/off) and level indication modes (AVERAGE, RMS, MAX PEAK, SAMPLE), become effective at different points in signal processing. This is explained in greater detail in the following section, which discusses the R&S®PR100's functional principle based on block diagrams.

Structure of R&S®PR100 configuration menus

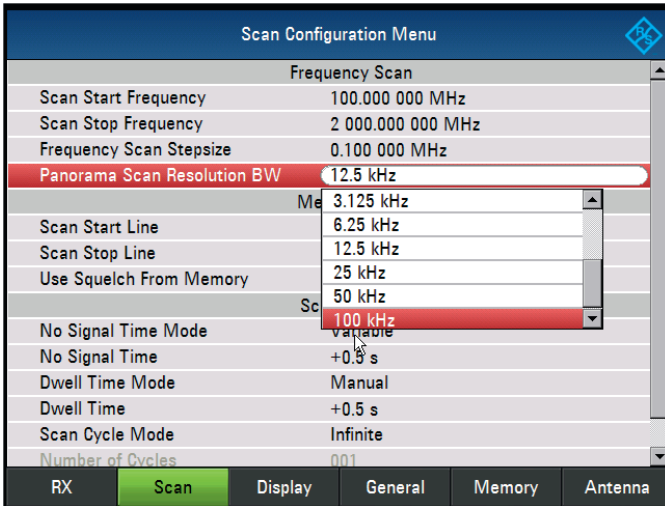

Display of measured level and IF spectrum

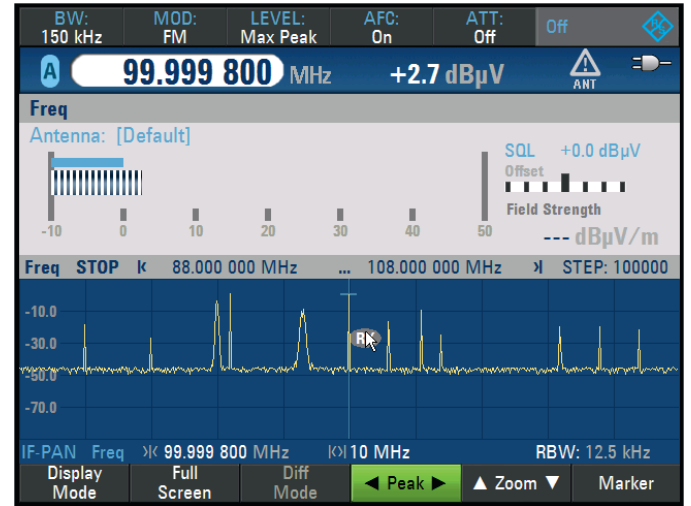

IF spectrum analysis by means of marker functions

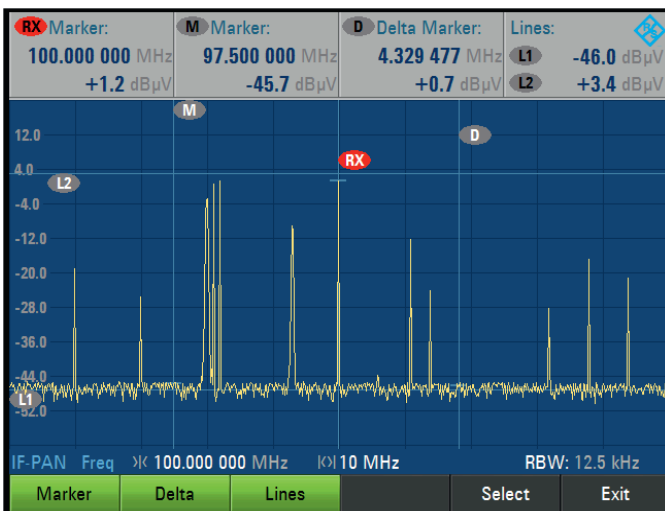

Display of IF spectrum and spectrogram (waterfall display)

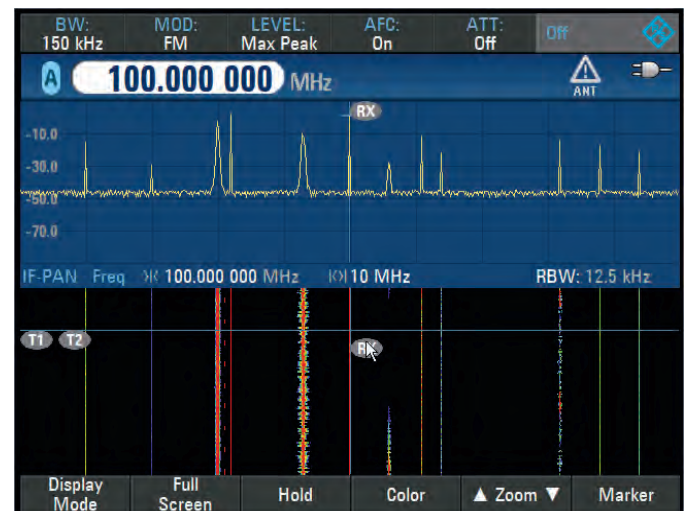

Operating principle

Digital signal processing

After A/D conversion of the signal, the signal path is split up:

In the first path, the IF spectrum is calculated by means of a digital downconverter (DDC), a digital bandpass filter and an FFT stage. The bandwidth of the bandpass filter can be selected between 10 kHz and 10 MHz. Before the IF spectrum is output on the display or via the LAN interface, results are postprocessed by means of the AVERAGE, MIN HOLD or MAX HOLD function as selected by the user.

In the second path, the signal is processed for level measurement or demodulation. Here, too, the signal is taken via a DDC and a bandpass filter. To process the different signals with optimum signal-to-noise ratio, the receiver contains IF filters with demodulation bandwidths from 150 Hz to 500 kHz, which can be selected independently of the IF bandwidth.

Prior to the level measurement, the absolute value of the level is determined and weighted by means of the AVERAGE, MAX PEAK, RMS or SAMPLE function, as selected by the user. The measured level is then output on the display or via the LAN interface.

For the demodulation of analog signals, the complex baseband data is subjected to automatic gain control (AGC) or manual gain control (MGC) after the bandpass filter. It is then applied to the AM, FM, USB, LSB, ISB, PULSE or CW demodulation stage. The complex baseband data (I/Q data) of digital signals is directly output for further processing after the AGC/MGC stage.

Frontend

Starting from the antenna socket, the frequency in the signal path is limited to 8 GHz. Signal processing then takes place in three paths for three different frequency ranges.

Signals from 9 kHz to 30 MHz are routed via a preamplifier directly to the A/D converter. Signals from 20 MHz to 3.5 GHz are taken to the IF section via a preselection and a preamplifier, or via an attenuator in the case of high signal levels. The preselection as well as the attenuator effectively protect the IF section against overloading. This is particularly important in this frequency range, where the maximum signal sum levels occur. Signals from 3.5 GHz to 8 GHz are taken to the IF section via a preamplifier.

The three-stage IF section processes the signals from 20 MHz to 8 GHz for the subsequent A/D converter. To provide optimum instrument performance, only signals up to 7.5 GHz are processed in the subsequent stages. The uncontrolled 21.4 MHz IF can also be tapped ahead of the A/D converter via a BNC socket of the R&S®PR100 for further external processing.

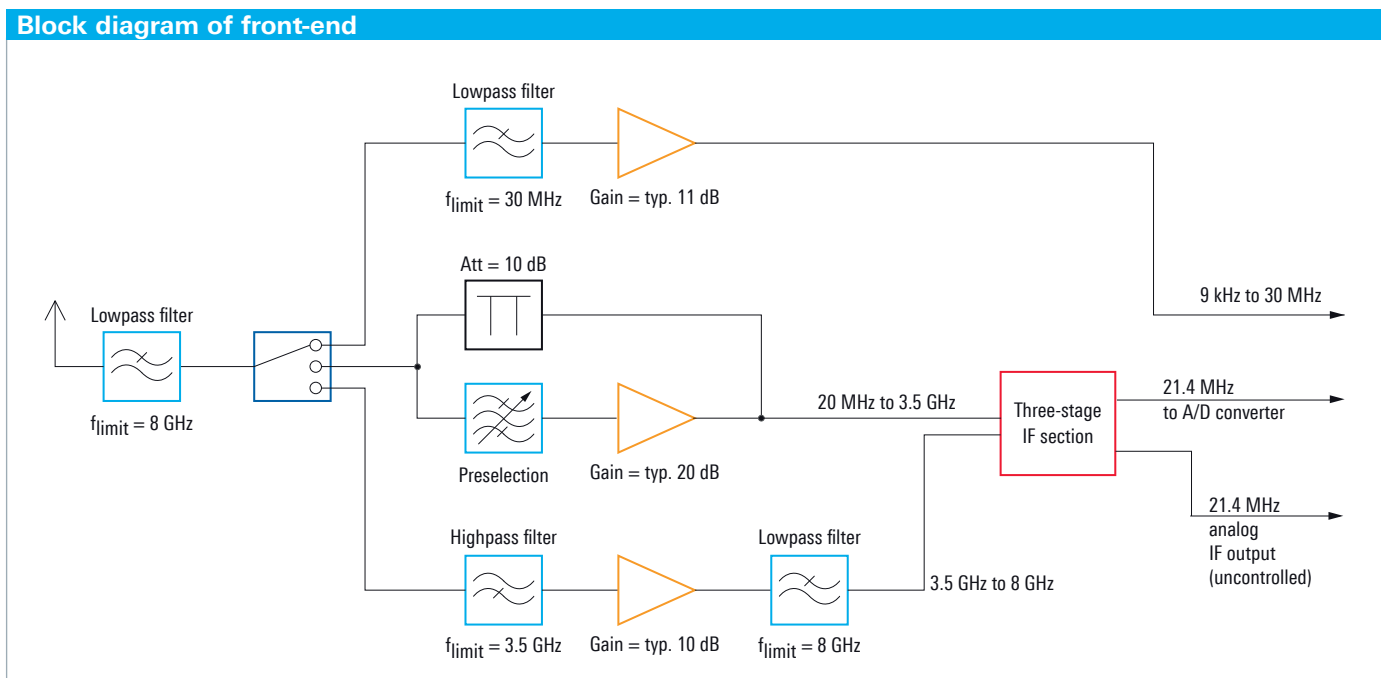

The results obtained are available as digital data and can be output via the LAN interface as required for the particular task. Digital audio data are reconverted to analog signals for output via the loudspeaker.

High receiver sensitivity, high signal resolution

The R&S® PR100 features an IF bandwidth of up to 10 MHz. This allows even very short signal pulses to be captured since the receiver displays the large bandwidth of 10 MHz in a single spectrum about the set center frequency without any scanning being required.

The widest IF bandwidth of 10 MHz yields the widest spectral display; the narrowest IF bandwidth of 10 kHz yields maximum sensitivity.

The IF spectrum is digitally calculated by means of a Fast Fourier Transform (FFT). The use of FFT computation at the IF offers a major advantage: The receiver sensitivity and signal resolution are clearly superior to those of a conventional analog receiver at the same spectral display width.

IF spectrum

FFT calculation of the IF spectrum is performed in a number of steps. These are described below in simplified form for an IF bandwidth of 10 kHz ($BW_{IF\ spectrum} = 10\ kHz$), which yields maximum sensitivity.

Due to the finite edge steepness of the IF filter, the sampling rate f_s must be larger than the selected IF bandwidth $BW_{IF\ spectrum}$. The quotient of the sampling rate and the IF bandwidth is thus a value > 1 and is a measure of the edge steepness of the IF filter. This relationship is expressed by the following two formulas:

$$\frac{f_s}{B_{IF\ spectrum}} = \text{const}$$

or

$$f_s = BW_{IF\ spectrum} \cdot \text{const}$$

The value of the constant is dependent on the selected IF bandwidth, i.e. it may vary as a function of the IF bandwidth.

For an IF bandwidth of $BW_{IF\ spectrum} = 10\ kHz$, the constant has a value of 1.28. To display a 10 kHz IF spectrum, therefore, a sampling rate of $f_s = 12.8\ kHz$ is required.

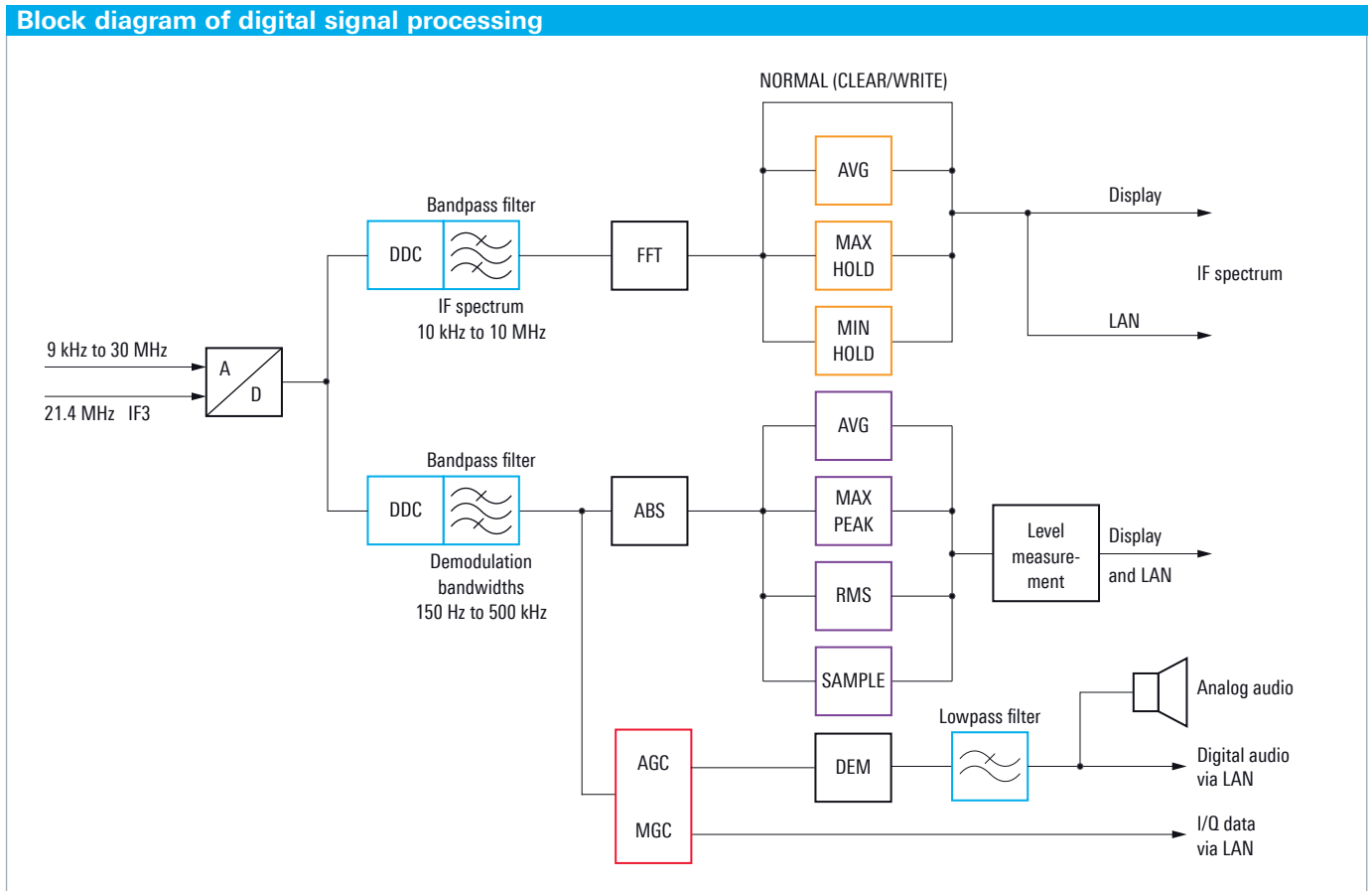

The R&S®PR100 uses an FFT length N of 2048 points to generate the IF spectrum. To calculate these points, the 12.8 kHz sampling band in the above example is divided into 2048 equidistant frequency slices, which are also referred to as "bins" (see figure "Signal processing for IF spectrum").

The bandwidth BW_{bin} of the frequency slices is obtained as follows:

$$BW_{bin} = \frac{f_s}{2048} = \frac{12.8 \text{ kHz}}{2048} = 6.25 \text{ Hz}$$

This means that in the above example only the calculated bandwidth of 6.25 Hz for each bin has to be taken into account as the noise bandwidth in the calculation of the displayed average noise level (DANL) in accordance with the formula below (the effect of the window function (Blackman window) of the FFT is not considered here for simplicity's sake):

$$DANL = -174 \text{ dBm} + NF + 10 \cdot \log(BW_{bin}/\text{Hz})$$

The quantity NF represents the overall noise figure of the receiver.

The above example shows that, due to the use of the FFT, the actual resolution bandwidth (RBW) to be taken into account in DANL calculation is clearly smaller (i.e. BW_{bin}) than would be expected for the wide display range of 10 kHz.

Another advantage of the high spectral resolution used in the FFT calculation is that signals located close together (e.g. f_1, f_2, f_3) can be captured and represented in the IF spectrum as discrete signals (see figure "Signal display in IF spectrum").

If, on an analog receiver, a resolution bandwidth equal to the set IF bandwidth were selected ($RBW = BW_{IF \text{ spectrum}}$), a sum signal f_{sum} would be displayed instead of the three discrete signals f_1, f_2 and f_3 .

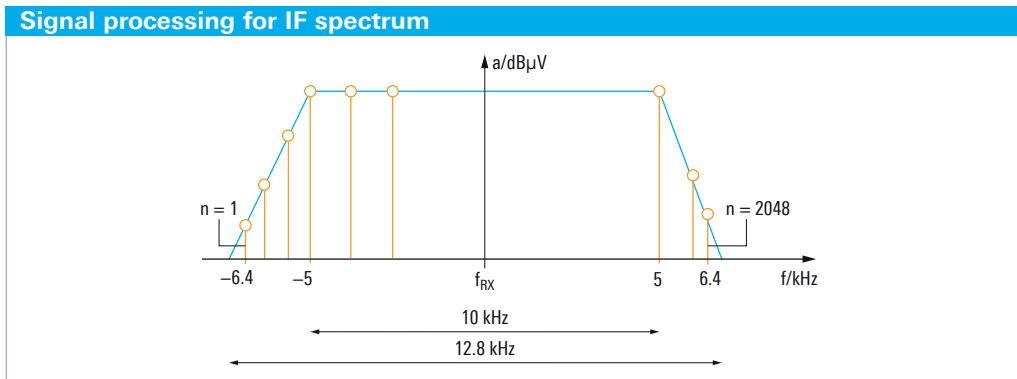

Actual sampling bandwidth compared with selected IF bandwidth

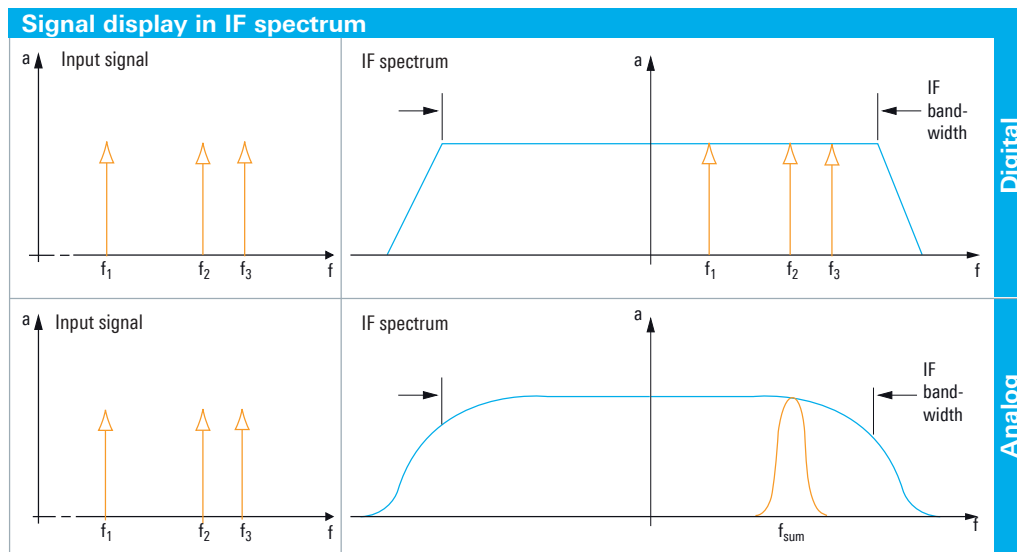

Signal resolution in IF spectrum with digital and analog receiver concept

Panorama scan

The receiver's maximum FFT bandwidth of 10 MHz makes it possible to perform extremely fast scans across a wide frequency range (panorama scan). For this purpose, frequency windows of max. 10 MHz width are linked in succession, and thus the complete, predefined scan range is traversed (see figure "Signal processing in panorama scan mode"). Same as with the IF spectrum, an FFT is used to process the broad window with a finer resolution.

The width of the frequency window and the FFT length (number of FFT points) are variable and are selected by the receiver.

In the panorama scan mode, the user can select among 12 resolution bandwidths from 125 Hz to 100 kHz. The resolution bandwidth corresponds to the width of the frequency slices (bin width) mentioned under "IF spectrum" above. Based on the selected bin width and start and stop frequency, the R&S®PR100 automatically determines the required FFT length and the width of the frequency window for each scan step. The receiver selects these internal parameters so that the optimum scan speed is achieved for each resolution bandwidth (see figure "Resolution in panorama scan mode").

In the panorama scan mode, the resolution bandwidth of 100 kHz yields the maximum scan speed, while the resolution bandwidth of 125 Hz yields maximum sensitivity.

The resolution bandwidth (bin width) for the panorama scan (selectable between 125 Hz and 100 kHz) therefore corresponds to the resolution bandwidth (BW_{bin}) used in the DANL calculation for the IF spectrum (see DANL formula under "IF spectrum" above), and can thus be used for calculating the DANL for the panorama scan. Moreover, the user selects the resolution bandwidth to obtain the desired frequency resolution (see figure "Bin width and channel spacing").

The above explanations show that the use of digital signal processing in a monitoring receiver offers decisive advantages. Extremely high sensitivity (due to very fine resolution) combines with a broad spectral overview and high scan speed to significantly increase the probability of intercept over an analog receiver.

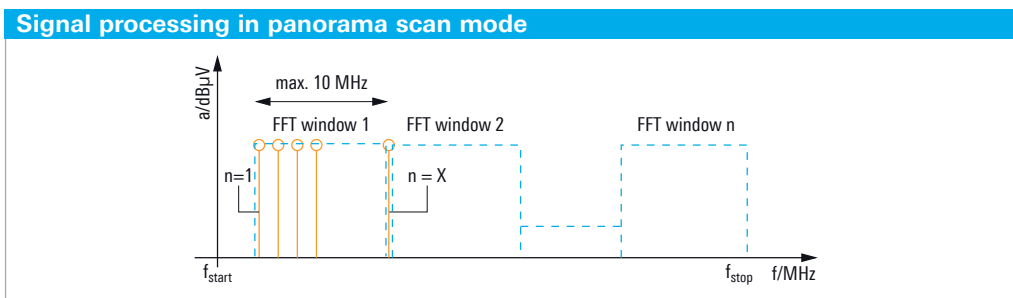

Basic sequence of steps in fast panorama scan mode

Selection of resolution for panorama scan by varying the bin width

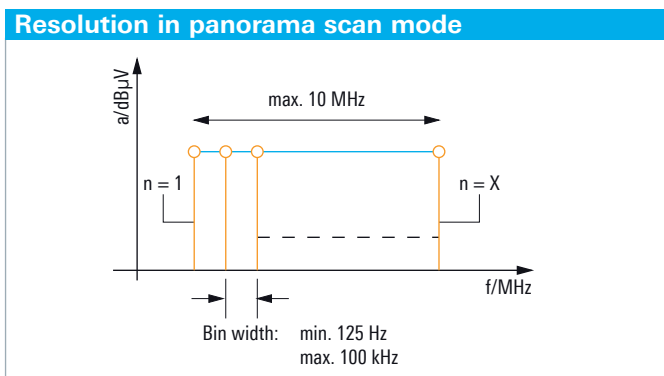

Selection of 12.5 kHz bin width to capture a radio service using 12.5 kHz channel spacing

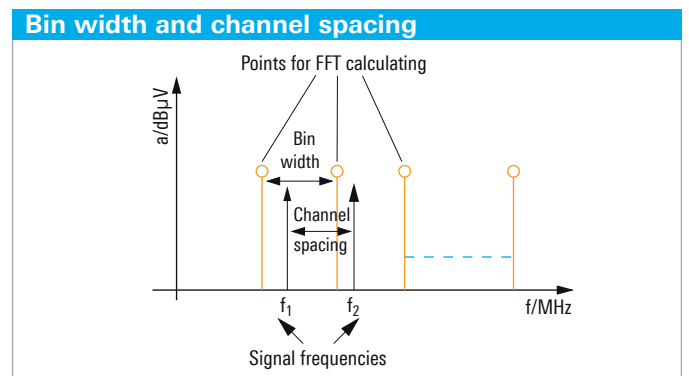

R&S®HE300 active directional antenna

The antenna covers the extremely wide frequency range from 9 kHz to 7.5 GHz by means of four plug-in modules. Three of these modules, which cover the range from 20 MHz to 7.5 GHz, are supplied with the antenna. The R&S®HE300HF antenna module is available as an HF option, covering the lower frequency range from 9 kHz to 20 MHz.

Portable monitoring and measuring system

The R&S®HE300 active directional antenna and the R&S®PR100 portable receiver together form a powerful receiving system for locating transmitters. The portable and lightweight instrument combination can perform measurements in buildings or in rough terrain that even four-wheel-drive vehicles cannot access. The cost-effective monitoring system, featuring position finding and level measurement, offers another decisive advantage: It can be transported and deployed relatively inconspicuously.

For long-term monitoring at fixed locations, the antenna can be mounted on a tripod. The connecting thread on the grip piece matches the mounting bolts of conventional camera tripods.

A built-in, switchable low-noise amplifier further enhances system sensitivity at low signal field strengths, thus increasing the probability of intercept (active mode). In the passive mode, the amplifier is bypassed, so that the antenna can also be used in the vicinity of strong signal sources.

Ergonomic design for practical use

The design of the grip piece and the control elements underwent extensive ergonomic testing by experienced designers. The antenna modules are exchangeable; the required module is plugged into the grip piece in accordance with the desired polarization and mechanically locked. All R&S®HE300 components plus the optional R&S®HE300HF antenna module and the R&S®PR100 receiver are accommodated in a rugged hard-shell transit case, which is supplied with the antenna and offers appropriate protection even under the harshest transport conditions.

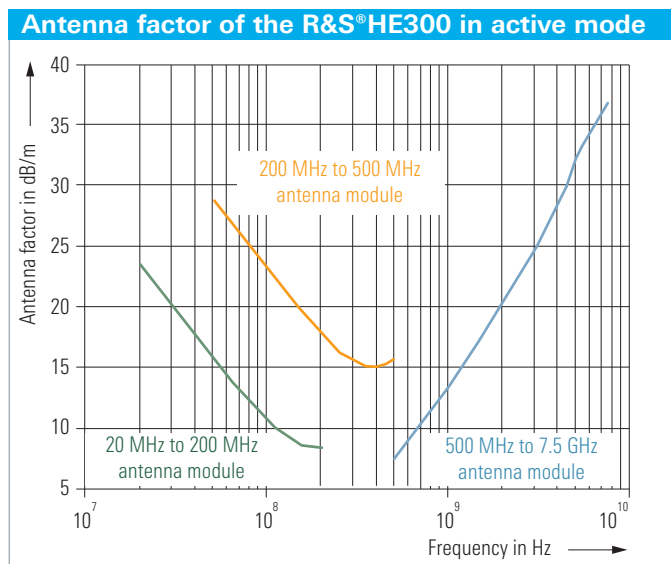

Key data of the R&S®HE300	
Frequency range	
Antenna module 1	20 MHz to 200 MHz
Antenna module 2	200 MHz to 500 MHz
Antenna module 3	500 MHz to 7.5 GHz
HF antenna module (optional)	9 kHz to 20 MHz
Polarization	linear
VSWR	<2.5 (typ.)
RF output	N connector
Power supply	rechargeable cells or batteries
Overall weight	approx. 6 kg (including transit case)
Operational weight	<1 kg (grip piece with one module)

Specifications

RF data		
Frequency range		9 kHz to 7.5 GHz
RF input		
Input level		typ. 0 dBm
Impedance		50 Ω
VSWR	9 kHz to 3.5 GHz	$\leq 2:1$
	3.5 GHz to 7.5 GHz	$\leq 3:1$
Input attenuation		typ. 10 dB, effectively 25 dB (can be switched manually)
Preselection		
	9 kHz to 30 MHz	30 MHz lowpass filter
	20 MHz to 3.5 GHz	tuned bandpass filters
	3.5 GHz to 7.5 GHz	highpass/lowpass filter combination
Noise figure		
	9 kHz to 200 kHz	typ. 20 dB
	200 kHz to 20 MHz	typ. 14 dB
	20 MHz to 1.5 GHz (attenuator off)	typ. 10 dB
	1.5 GHz to 3.5 GHz (attenuator off)	typ. 10 dB
	3.5 GHz to 7.5 GHz	typ. 18 dB
Third-order intercept (TOI) (input)		
	At ≥ 1 MHz test signal offset	
	20 MHz to 650 MHz (attenuator on)	typ. 17 dBm
	650 MHz to 3.5 GHz (attenuator on)	typ. 21 dBm
	3.5 GHz to 7.5 GHz	typ. -2 dBm
Phase noise		
	$\Delta f = 10$ kHz, $f_c = 500$ MHz	typ. -94 dBc/Hz
	$\Delta f = 100$ kHz, $f_c = 500$ MHz	typ. -104 dBc/Hz

IF data		
IF spectrum display range		10 kHz to 10 MHz
Display mode		NORMAL (CLEAR/WRITE), AVERAGE, MAX/MIN HOLD
IF demodulation bandwidths	15 filters (specified values indicate 3 dB bandwidth)	150/300/600 Hz 1.5/2.4/6/9/15/30/50/120/150/200/300/500 kHz
Demodulation modes		
	AM	USB (demodulation bandwidths ≤ 9 kHz)
	FM	LSB (demodulation bandwidths ≤ 9 kHz)
	PULSE	ISB (demodulation bandwidths ≤ 15 kHz)
	I/Q	CW (demodulation bandwidths ≤ 9 kHz)

Control		
Squelch	in 1 dB steps	-30 dB μ V to +110 dB μ V
Gain control	AGC	-30 dB μ V to +110 dB μ V
	MGC	-30 dB μ V to +110 dB μ V
Frequency control	AFC	$\pm 1/2$ IF bandwidth (150 Hz to 500 kHz)

Signal processing		
FFT (Fast Fourier Transform)		2048 points
		Blackman window
		max. 20 data sets/s on the display
		max. 200 data sets/s via LAN

Scan modes		
Frequency scan	start/stop frequency, step width	user-selectable
Memory scan	memory locations	1024, user-programmable
Panorama scan	start/stop frequency	user-selectable
	resolution bandwidths (bin widths)	125/250/500/625 Hz 1.25/2.5/3.125/6.25/12.5/25/50/100 kHz

Measurement accuracy and display modes

Frequency resolution		1 Hz
Frequency accuracy	across specified operating temperature range	±1 ppm
	aging	±1 ppm/year
Signal level	0.1 dB resolution	-30 dBμV to +107 dBμV, -137 dBm to 0 dBm
Display error		max. ±3 dB/typ. ±1.5 dB
Level display modes		AVERAGE, RMS, MAX PEAK, SAMPLE
A/D converter		14 bit

Interfaces

Antenna input	9 kHz to 7.5 GHz	N socket, 50 Ω
Max. level	non-destructive	+20 dBm, 0 V DC
Reference input	10 MHz	BNC socket, typ. 500 Ω
Max. level	non-destructive	0.1 V (V_{pp}) to 3 V (V_{pp}), max. 5 V DC
IF output	for signals from 20 MHz to 7.5 GHz, uncontrolled	21.4 MHz, BNC socket, 50 Ω
I/Q output	bandwidth ≤500 kHz	LAN
Audio output, digital	bandwidth ≤12.5 kHz	LAN
Audio output, analog	dependent on IF filter and modulation type	10 Hz/300 Hz to 12.5 kHz
Data and control interfaces	remote control and data transfer	LAN (Ethernet 10/100BaseT)
	read and write to SD card	USB 1.1
Screenshots	file format	PNG

Standards

EMC	electrical safety	EN61010
	EMI, EMS	R&TTE EN301489.1/22 EN55022, Class B (valid for LAN cable lengths <3 m)
Mechanical stress	vibration (sine), vibration (random), shock	MIL-PRF 28800 F
Environmental stress	operating altitude, humidity, etc.	MIL-PRF 28800 F

General data

Operating temperature range	with battery	0°C to +50°C
	with external power supply unit	0°C to +40°C
Permissible temperature range	with battery	-10°C to +50°C (without condensation)
Power supply	AC, with external power supply unit	100 V AC to 240 V AC, 50 Hz/60 Hz, 700 mA
	DC	15 V DC ±10%, 2 A
Battery (lithium-ion, 6 cells)	operating time	approx. 4 hours
	charging time	approx. 4 hours
Dimensions	height × width × depth	approx. 320 mm × 192 mm × 62 mm
Weight	including battery	approx. 3.5 kg

Ordering information

Base unit

Designation	Type, description	Order No.
Portable Receiver	R&S®PR100	4071.9006.02
Equipment and functions included	IF spectrum (max. 10 MHz), spectrogram (waterfall display), 6-cell lithium-ion battery, plug-in power supply, SD card for storing user settings, shoulder strap	
Documentation of Calibration-Values	R&S®PR100-DCV	4071.9906.02
		available as of 10/2008

Software options

Designation	Type, description	Order No.
Panorama Scan	R&S®PR100-PS	4071.9306.02
Equipment and functions included	RF scan, high-speed FFT scan across user-selectable scan range, selectable spectral resolution (bin width)	available as of 07/2008
Internal Recording	R&S®PR100-IR	4071.9358.02
Equipment and functions included	recording of measured data in the receiver (64 MB RAM) or on SD card, 4 GB SD card, recording of audio data in WAV format (replay by means of Windows Media Player, for example), recording of I/Q data, spectra and spectrogram (waterfall) data, RxView software for viewing measured data on customer PC, data transfer from SD card to PC via USB interface	available as of 04/2009
Remote Control	R&S®PR100-RC	4071.9406.02
Equipment and functions included	remote control of receiver via LAN interface (SCPI protocol), RxView and RxControl software; the RxControl software does not include the complete remote-control functionality; this has to be created by customer by means of SCPI commands; transfer of measured data via LAN interface; transfer of demodulated I/Q data (up to 500 kHz bandwidth) via LAN interface	available as of 12/2008
Externally Triggered Measurements	R&S®PR100-ETM	4071.9458.02
Equipment and functions included	an external sensor (not supplied with the receiver) triggers a measurement in the R&S®PR100; the sensor is connected via the AUX interface	available as of 06/2009
Field Strength Measurement	R&S®PR100-FS	4071.9506.02
Equipment and functions included	the field strength is calculated using antenna factors stored in the receiver; the receiver displays the field strength directly in dBµV/m	available as of 07/2008
SHF Frequency Processing for downconverter antennas	R&S®PR100-FP	4071.9558.02
Equipment and functions included	the downconverter unit of the R&S® HF907DC antenna is connected to the receiver via a control cable; the receiver recalculates the downconverted signals to display them with their original frequencies up to 18 GHz and with the sidebands in their original positions, thus relieving the user from having to convert signals subsequently	available as of 06/2009

Accessories

Designation	Type, description	Order No.
Battery Pack	R&S®PR100-BP	4071.9206.02
Equipment included	6-cell lithium ion battery, charging cradle, plug-in power supply	
Suitcase Kit	R&S®PR100-SC	4071.9258.02
Equipment included	hard-shell transit case with headphones and telescopic antenna and extra space for accessories	
Carrying Holster		1309.6198.00
Soft Carrying Bag		1309.6175.00
Active Directional Antenna	R&S®HE300	4067.5900.02
Equipment included	three antenna modules covering the range from 20 MHz to 7.5 GHz, grip piece housing switchable preamplifier, hard-shell transit case with extra space for R&S®PR100	
HF Option for R&S®HE300	R&S®HE300-HF	4067.6806.02
Equipment included	loop antenna from 9 kHz to 20 MHz for R&S®HE300 active directional antenna	

Service you can rely on

- | In 70 countries
- | Person-to-person
- | Customized and flexible
- | Quality with a warranty
- | No hidden terms

About Rohde & Schwarz

Rohde & Schwarz is an independent group of companies specializing in electronics. It is a leading supplier of solutions in the fields of test and measurement, broadcasting, radiomonitoring and radiolocation, as well as secure communications. Established 75 years ago, Rohde & Schwarz has a global presence and a dedicated service network in over 70 countries. Company headquarters are in Munich, Germany.

Regional contact

Europe, Africa, Middle East

+49 1805 12 42 42* or +49 89 4129 137 74

customersupport@rohde-schwarz.com

North America

1-888-TEST-RSA (1-888-837-8772)

customer.support@rsa.rohde-schwarz.com

Latin America

+1-410-910-7988

customersupport.la@rohde-schwarz.com

Asia/Pacific

+65 65 13 04 88

customersupport.asia@rohde-schwarz.com

Certified Quality System
ISO 9001
DQS REG. NO 1954 QM

Certified Environmental System
ISO 14001
DQS REG. NO 1954 UM

More information at
www.rohde-schwarz.com
(search term: PR100)

Rohde & Schwarz GmbH & Co. KG

Mühldorfstraße 15 | 81671 München

Phone +49 89 41 290 | Fax +49 89 41 29 121 64

www.rohde-schwarz.com

R&S® is a registered trademark of Rohde & Schwarz GmbH & Co. KG
Trade names are trademarks of the owners | Printed in Germany (kr)
PD 5213.9870.32 | Version 01.00 | June 2008 | R&S®PR100
Data without tolerance limits is not binding | Subject to change

*0.14 €/min within German wireline network; rates may vary in other networks (wireline and mobile) and countries.